

owner's manual

IMPORTANT SAFETY INSTRUCTIONS

WARNING: READ THIS FIRST!

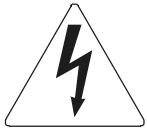

This symbol is intended to alert the user to the presence of uninsulated "dangerous voltage" within the product's enclosure that may be of sufficient magnitude to constitute a risk of electric shock to persons.



This symbol is intended to alert the user to the presence of important operating and maintenance (servicing) instructions in the literature accompanying the appliance.

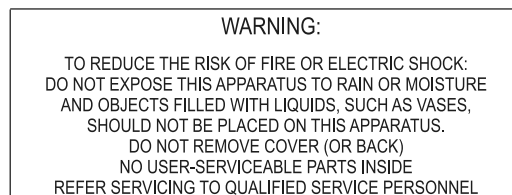

"INSTRUCTIONS PERTAINING TO A RISK OF FIRE, ELECTRIC SHOCK OR INJURY TO PERSONS"

WARNING:

- 1) Read these instructions.
- 2) Keep these instructions.
- 3) Heed all warnings.
- 4) Follow all instructions.
- 5) Do not use this apparatus near water.
- 6) Clean only with dry cloth.
- 7) Do not block any ventilation openings. Install in accordance with the manufacturer's instructions.
- 8) Do not install near any heat sources such as radiators, heat registers, stoves or other apparatus (including amplifiers) that produces heat.
- 9) Do not defeat the safety purpose of the polarized or grounding-type plug. A polarized plug has two blades with one wider than the other. A grounding type plug has two blades and a third grounding prong. The wider blade or the third prong are provided for your safety. If the provided plug does not fit in to your outlet, consult an electrician for replacement of the obsolete outlet.
- 10) Protect the power cord from being walked on or pinched, particularly at plugs, convenience receptacles, and the point where they exit from the apparatus.
- 11) Only use attachments/accessories specified by the manufacturer.
- 12) Use only with the cart, stand, tripod, bracket, or table specified by the manufacturer, or sold, with the apparatus. When a cart is used, use caution when moving the cart/apparatus combination to avoid injury from tip-over..
- 13) Unplug this apparatus during lightning storms or when unused for long periods of time.
- 14) Refer all servicing to qualified service personnel. Servicing is required when the apparatus has been damaged in any way, such as power-supply cord or plug is damaged, liquid has been spilled or objects have fallen into the apparatus, the apparatus has been exposed to rain or moisture, does not operate normally, or has been dropped.



NOTE: The socket-outlet shall be installed near the equipment and shall be easily accessible.

SAVE THESE INSTRUCTIONS

Fig. 1

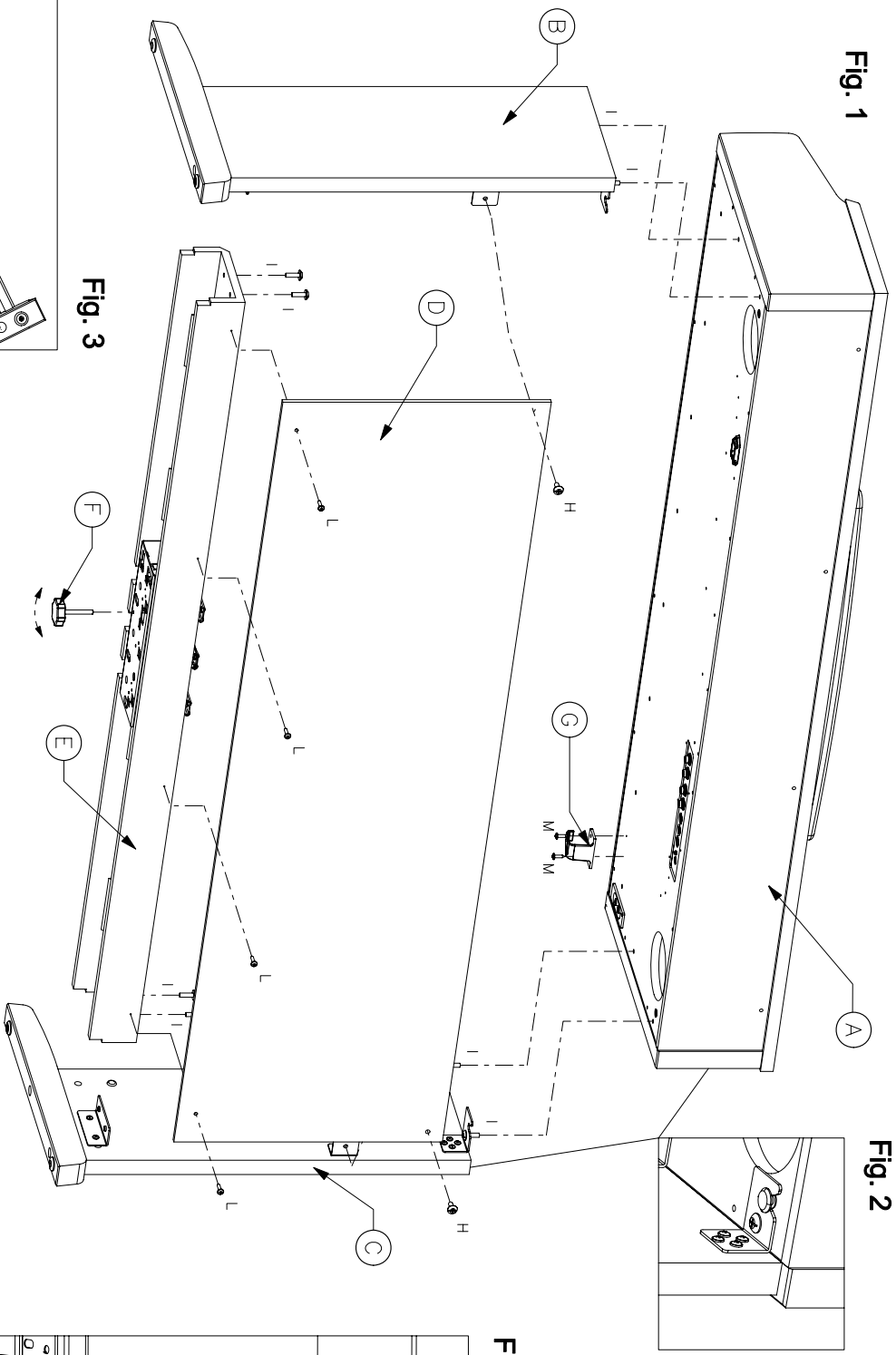

Fig. 2

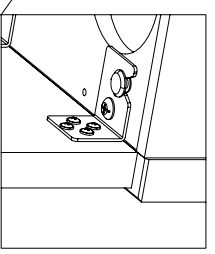

Fig. 3

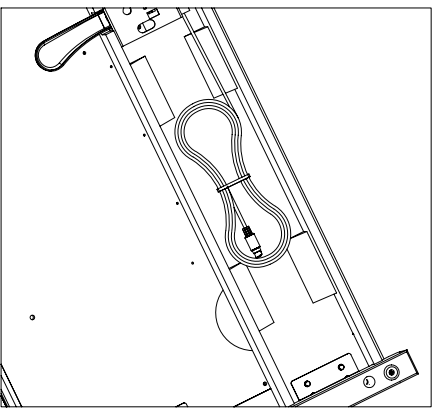
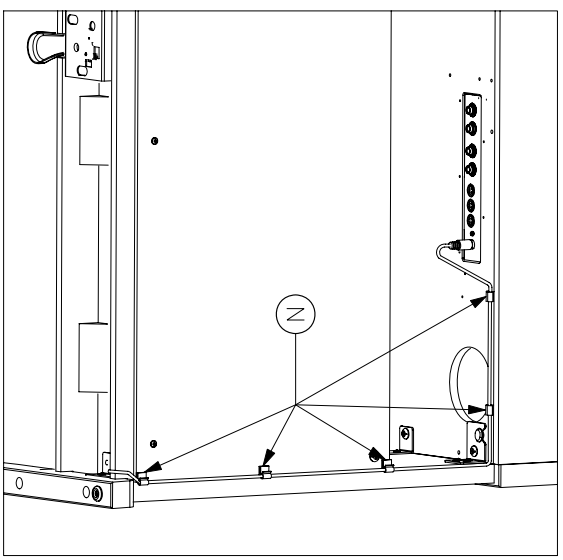

Fig. 4



Assembly instruction VP111

1) Make sure you have the following parts, which are supplied in the package:

- A)** Piano cabinet
- B)** Right Leg
- C)** Left Leg
- D)** Rear Panel
- E)** Bottom crossbar with three pedals group
- F)** Pedal clog
- G)** Headphone hang

and the fixing accessories to be found into a nylon bag:

- H)** M6x20 TC screw (2x)
- I)** M6x20 TC screw (8x)
- L)** WL 4x20 TC screw (4x)
- M)** WL 4x12 TC screw (2x)
- N)** Adhesive clamp (5x)
- O)** Phillips screwdriver

2) Remove the nylon protection and white foam on the wooden parts, free the pedals cable under the crossbar as shown in Fig. 3

3) Fix on pedals group the pedal clog (F) as shown in Fig.1.

4) Fix the right leg (B) to crossbar (E) with screws (I).

5) Fix the left leg (C) to crossbar (E) with screws (I).

6) Fix the rear panel (D) to the crossbar (E) with screws (L) and to the legs (B) and (C) with screws (H) as shown in Fig.1.

7) Place the piano cabinet (A) on stand, fix it with screws (I) as shown in Fig.1 by paying particular attention to the position of the hook, as shown in Fig.2.

8) Fix the headphone hang (G) with screws (M) as Fig. 1

9) Attach the adhesive clamps (N) as shown in Fig.4

10) Insert the MINI DIN pedals cable plug into the proper socket of I/O group under the pianocabinet (A) and fix the cable on the adhesive clamp (N) of Fig. 4.

11) Place the piano in its final location and adjust on floor the clog (F) of pedals group.

Assembly Instruction VP91

Make sure you have the following parts, which are supplied in the package:

- 1) Damper Pedal
- 2) Music Rest
- 3) Power Chord

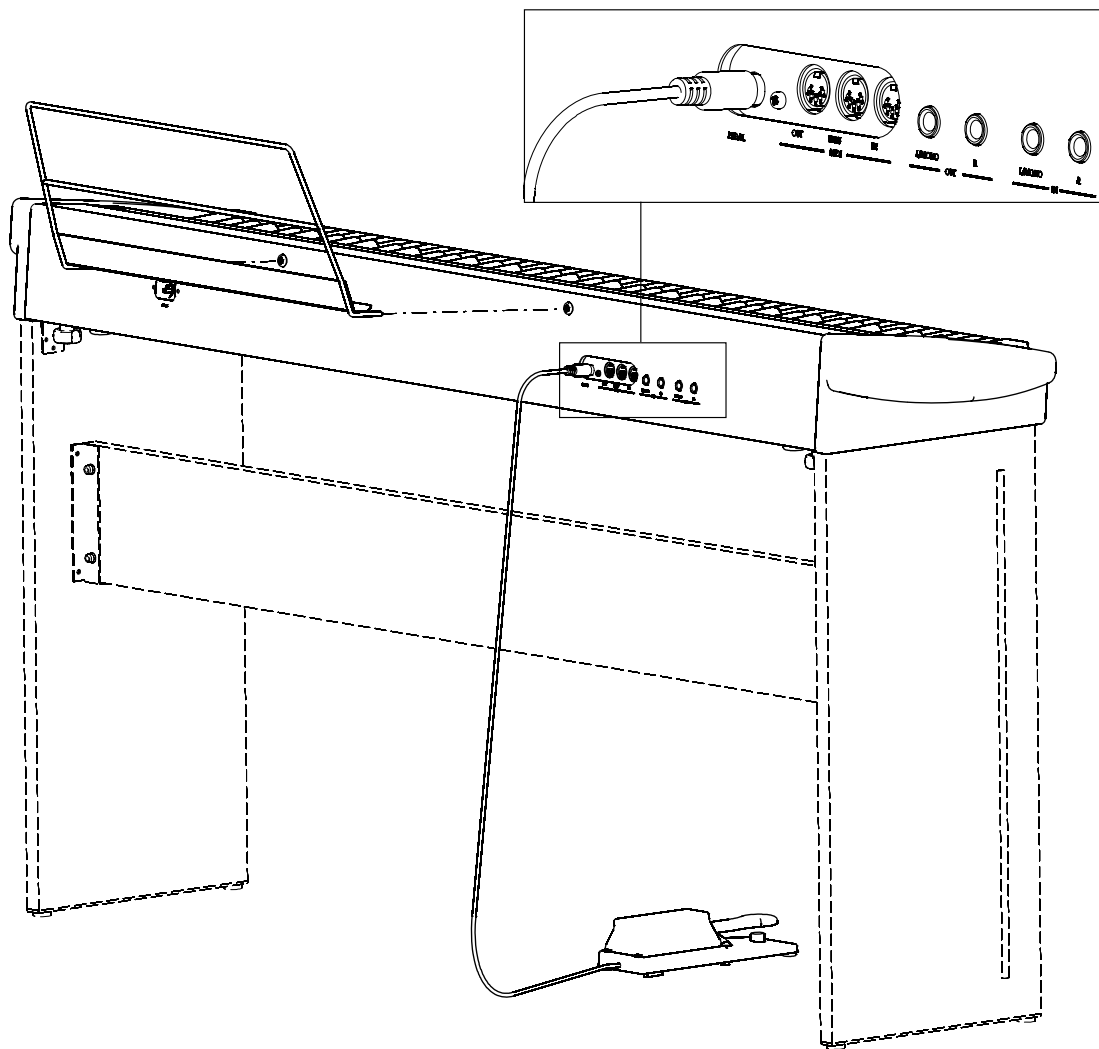

***STAND OPTIONAL**

Table of Contents

CONTROL PANEL	1
Turn the power on	2
Master volume set up	2
Connecting headphones	2
Demo listening	2
Presets selection	3
METRONOME: playing with a metronome guide	3
Preset List	3
TRANSPOSE: to change the instruments tranposition	4
Function and controls.....	4
Functions menu	4
Function edit menu	5
Dynamic curve selection: TOUCH	5
Tune edit: TUNE	5
Temperaments selection: TEMPERAMENTS	6
T. Signature	6
Effects on/off: EFFECT	7
MAF on/off: Mechanical Acoustic Feel	7
Equalizer on/off: EQUALIZER	7
MIDI	8
Back-Up on/off: Back Up.....	8
Vocal guide on/off: VOICE	9
VP111 connections: REAR PANNEL.....	9
Technical Specifications	10
MIDI implementation chart	11

The illustrations and the screens of this manual are for instructional purposes only and may appear different from those on your instrument.

Congratulations! We thank you for selecting the all-new VP111/VP91 digital piano! Whether you are a student, teacher or professional, your piano will impress you with its musical quality and stylish design providing years of enjoyment. In addition, your digital piano is equipped with a high performance Hammer Action keyboard, for a realistic touch that allows you to express yourself in endless varieties of shade and color.

For these and many other reasons, you will discover your VP111/VP91 is an absolute pleasure to play!

To get the absolute most out of your new piano, we recommend that you read this manual carefully so that you can take full advantage of all the advanced and convenient functions. We also recommend that you keep this manual in a safe and handy place for quick and easy reference in the future.

If you're enjoying your piano, please tell a friend!

CONTROL PANEL

All the functions of your digital piano can be found on the control panel which is located on the left side of the piano keyboard.

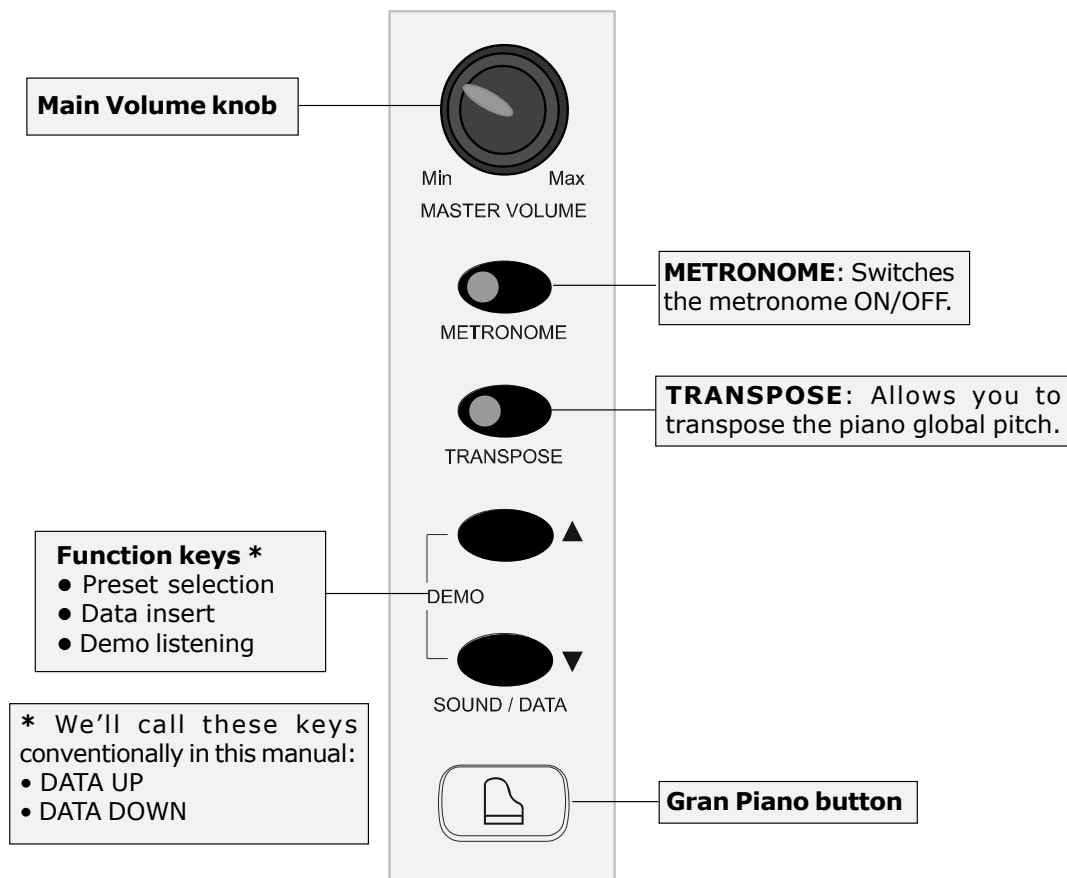

Turn the power on

Connect your piano to an appropriate AC outlet and switch it on using the power button located on the right hand side of the keyboard.

Wait a couple of seconds while your piano powers up. The Grand Piano button will illuminate indicating the default sound.

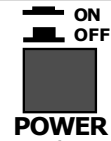
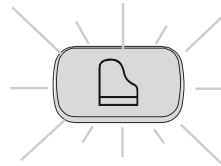

Master volume set up

Turn the volume knob on the control panel to set your piano volume. Turning the knob to the left will decrease the volume and turning it to the right will increase the volume.

Warning! Excessive volume (especially with headphones connected) can be harmful to your hearing.



Connecting headphones

In addition to the internal amplification system, You can connect two sets of standard stereo headphones.

The headphone inputs are located under the left-hand side of the keyboard.

- The headphone connection disables the internal speaker system
- The Main volume knob adjusts the headphone volume.

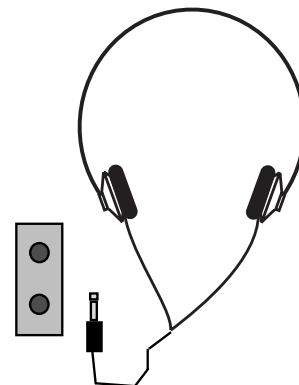

Demo listening

Your VP111/VP91 features some built-in demo songs, that you can play by following this procedure:

Start the demo sequence by pressing the two **DATA UP/DOWN** buttons AT THE SAME TIME.

Press the two **DATA UP/DOWN** buttons again to STOP the demo sequence.

Press **DATA UP** to select next demo song.

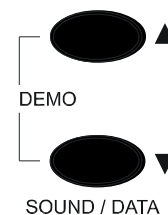

Sound selection

The sound presets are the internal sounds of your VP111/VP91. These sounds are optimized with associated effects and control parameters.

First, power on the instrument (GRANDPIANO is automatically selected).

Press the DATA UP button to change the instrument presets.

Each time the button is pressed, the next preset is recalled (there are 16 available presets - 11 single + 5 combination).

Using both the DATA UP/DOWN buttons you can quickly select any preset in the menu.

Pressing the Grand Piano button on the control panel will return your piano to the GRANDPIANO sound.

default preset →

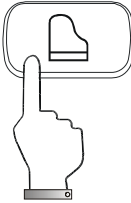

Pressing the Grand Piano button on the control panel the preset n.1 GRANDPIANO is recalled.

Preset List	
prg	Preset
1	Grand Piano (MAF)
2	El. Vintage Piano
3	FM Piano
4	Harpsichord
5	Clavi
6	Vibraphone
7	Nylon Guitar
8	Jazz Guitar
9	Slow Strings Ensamble
10	Choir
11	Warm Pad
12	Grand Piano dual Strings
13	Piano split Ac.Bass&Ride
14	Nylon Guitar dual Warm Pad
15	El. Vintage split El.Bass
16	Harpsichord dual Choir

Recall next preset

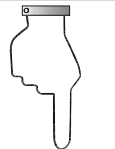

Recall previous preset

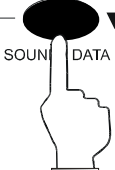

Using both DATA UP/DOWN buttons you can quickly select any preset in the menu.

METRONOME: playing with a metronome guide

Press the METRONOME button on the panel to enable your metronome. The button LED-light will start flashing. The default metronome tempo is 120 BPM (beats per minute) and has a range from 30 to 250 BPM.

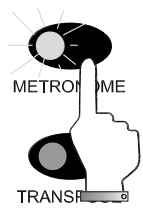

By pressing the METRONOME button for more than 2 seconds, the piano will enter the metronome tempo settings.

Set the metronome tempo by pressing the corresponding key in the keyboard in a range from 30 to 250 BPM.

Press the METRONOME button to exit the metronome settings.

Press the METRONOME button again to switch off the metronome click.

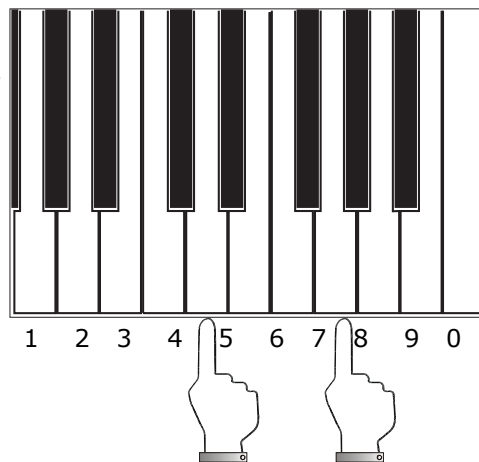

Use the TEMPO/DATA button to change the current beat value.

The numbers (1...0) are associated with the keys in the first octave of your pianokeyboard.

TRANPOSE: to change the instruments tranposition

You can transpose your piano by +/-12 semitones. Keep the TRANPOSE button on the control panel pressed for more than 2 seconds (the corresponding button indicator blinks):

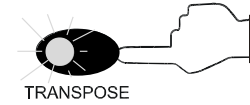

Press the SOUND/DATA buttons to change the current value.

Press the TRANPOSE button to exit the transpose edit status. The button indicator stops flashing but remains ON, to show the current transposed status of the piano.

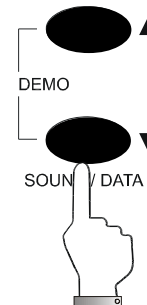

Press the TRANPOSE button again, to exit transpose, restoring the piano to normal status.

Function and controls

Your VP111/VP91 has functions and controls that allow you to adapt your piano to different operative needs and situations.

	Functions	Extension	Message	Note	default
1	Touch	Soft - Normal - Hard	Vocal Guide	A7	Normal
2	Tune	427,5 - 440 - 452,5 Hz	Reference Sine Signal	B7	440
3	Temperament	Equal, Meantone, Kirnberger	Vocal Guide	C8	Equal
4	Time signature	1/4 9/8	Audio Reference Signal	D8	4/4
5	Effects	ON/OFF	Vocal Guide	E8	ON
6	MAF	ON/OFF	Vocal Guide	F8	ON
7	Equalizer	ON/OFF	Vocal Guide	G8	ON
8	MIDI	01....16	Vocal Guide	A8	01
9	Back-up	ON/OFF	Vocal Guide	B8	OFF
10	Voice	ON/OFF	Vocal Guide	C9	ON

Functions menu

Being an extremely user-friendly instrument, the VP111/VP91's functions are easily activated. Each function is associated with one of the last two octave og keys on your piano keyboard.

The name of each function is printed under the corresponding key for your reference.

Each programming function can be enabled by pressing the associated keyboard key. While holding the selected key, the related function value can be changed by pressing DATA UP/DOWN buttons. For easy navigation and editing, your piano is equipped with a voice-help system which describes most of the functions and the parameters that have been recalled. When you release the keys associated to a function, the keyboard returns to normal mode.

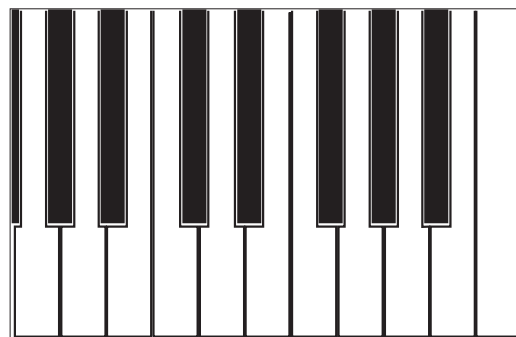

Touch Tune Temper. T.sign. Effects MAF Equ. MIDI Back-up Voice

Function edit menu

Dynamic curve selection: TOUCH

Press and hold the TOUCH (A7) function on the keyboard, and press the DATA UP button on the control panel.

Pressing the DATA button once, the vocal guide signals the current active touch value.

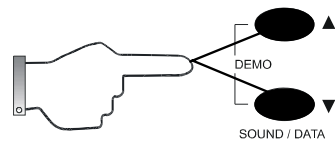
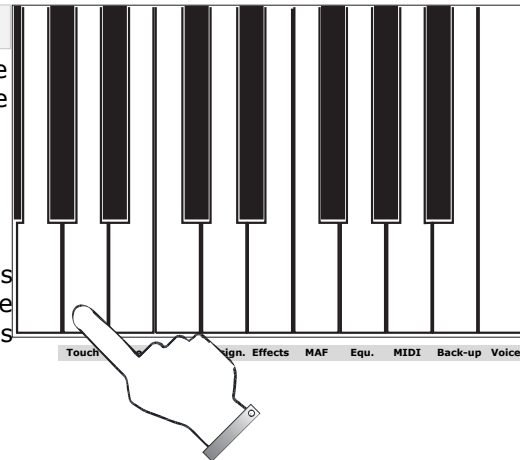
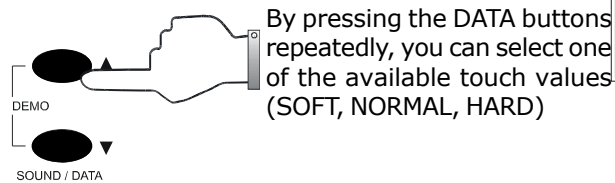

To select the default NORMAL curve, press the two DATA UP/DOWN buttons at the same time, while keeping the TOUCH function key (A7) on the piano keyboard pressed.

Tune edit: TUNE

This function allows you to modify the default standard tuning of your instrument (A=440 Hz). This is a very useful function when you play along with other musicians or singers, as it adjusts the instrument's tuning to their needs.

Press and hold the TUNE key on the piano keyboard (B7), and press the DATA UP button on the control panel.

The piano produces a sine (sinusoidal) reference signal at A=440 Hz. Each time you press the DATA UP button, this frequency will increase in steps of 1 cent, from A=440 Hz to A=452 Hz.

On the contrary, pressing the DATA DOWN button, the frequency will decrease in steps of 1 cent, in a range from A=440 Hz to A=427 Hz.

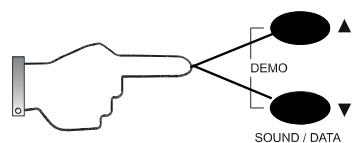
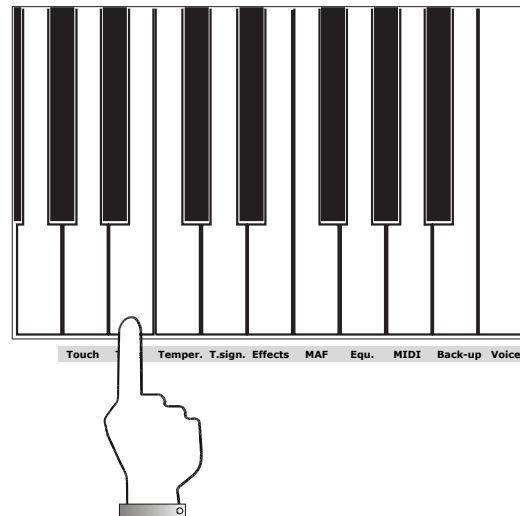
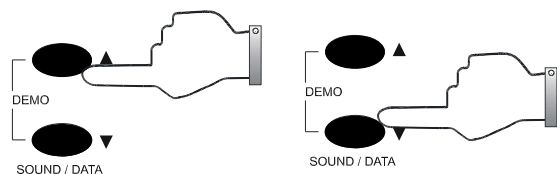

From any selection, the standard tune A=440 Hz can be recalled by simply pressing the two DATA UP/DOWN buttons at the same time, while pressing the function key TUNE (B7) on the piano keyboard.

Temperaments selection: TEMPERAMENTS

This function allows you to modify the current piano temperament (or 'tuning'). The default setting is EQUAL temperament, but other temperaments can easily be recalled.

Press the TEMPERAMENTS (C8) function key on the piano keyboard and the DATA button on the control panel. The vocal guide will tell you the current temperament selection, Pressing the DATA button again, it will be possible to recall the other temperaments.

1. Equal (default)
2. Meantone
3. Kirnberger

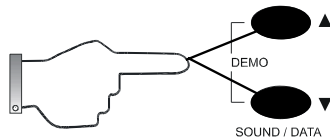
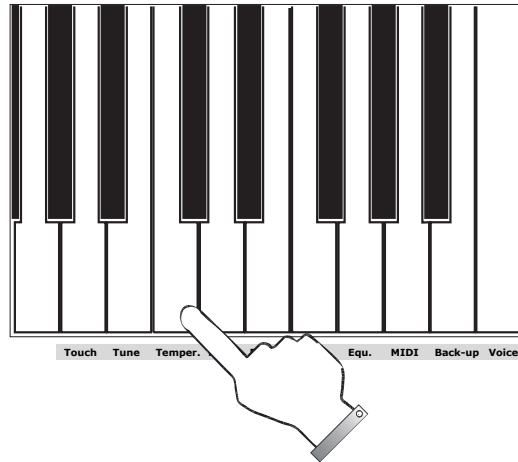

It is possible to restore the EQUAL temperament from any selection, by simply pressing the two DATA UP/DOWN buttons on the control panel at the same time, while pressing the function key TEMPERAMENTS (C8) on the piano keyboard.

T. Signature

This function allows you to modify the meter setting on your metronome. The default value corresponds to 4/4.

Press the T.sign. (D8) function key on the piano keyboard and the DATA button on the control panel. The metronome will properly signal the current subdivision, and the metronome led will start flashing.

Press the DATA UP/DOWN button to change the metrical subdivision ((1/4 - 2/4 - 3/4 - 4/4 - 5/4 - 6/4 - 7/8 - 3/8 - 6/8 - 7/8 - 9/8 - 12/8)).

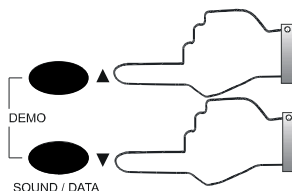
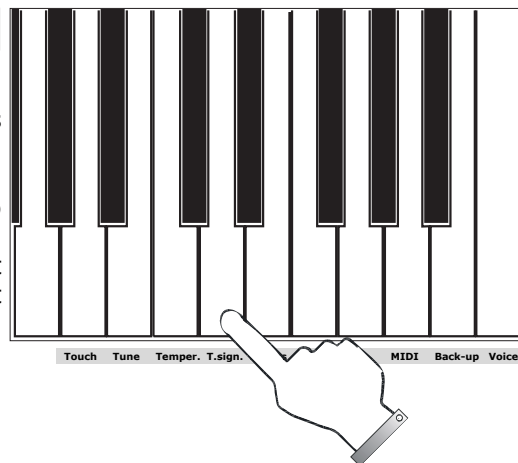

It's possible to restore 4/4 meter from any selection, by simply pressing the two DATA UP/DOWN buttons on the control panel at the same time, and keeping the function key T.sign (D8) pressed on the piano keyboard.

Effects on/off: EFFECT

Each of the sound presets on your VP111/VP91 are enriched with digital effects which are generated by the internal piano Sound Engine:

This menu allows you to disable or enable the effects. Keep the EFFECT (E8) function key on the keyboard pressed and press the DATA button on the panel. The vocal guide tells you the active effect status.

To change the effect status, keep the EFFECT (E8) function key on the keyboard pressed and press the DATA button on the panel. The vocal guide will tell you the status (EFFECTS ON or EFFECTS OFF). By default the function status is: EFFECTS ON (enabled).

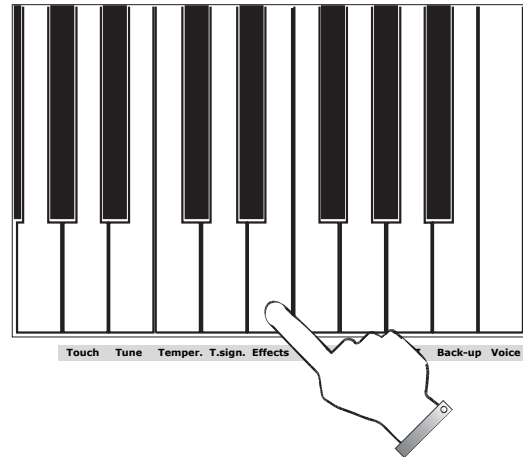
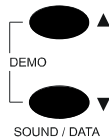

MAF on/off: Mechanical Acoustic Feel

This function allows you to enable or disable the MAF (Mechanical Acoustic Feel) effect. Keep the MAF (F8) function key on the keyboard pressed and press the DATA button on the panel. The vocal guide will tell you the MAF status.

To change the MAF status, keep the MAF (F8) function key on the keyboard pressed and press the DATA button on the panel. The vocal guide will tell you the status (MAF ON or MAF OFF). By default the function status is: MAF ON (enabled)

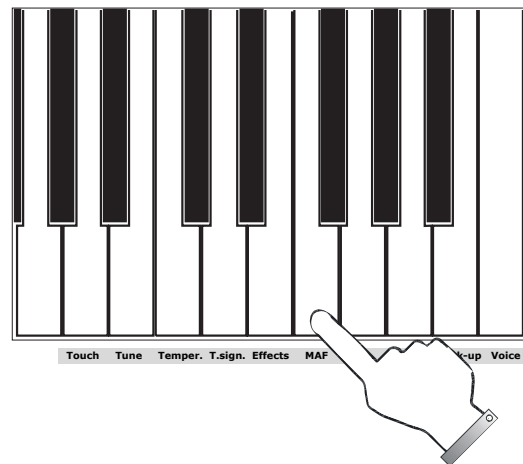
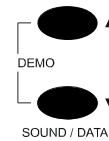

Equalizer on/off: EQUALIZER

This function allows you to enable or disable the internal equalizer.

Keep the EQUALIZER (G8) function key on the keyboard pressed and press the DATA button on the panel. The vocal guide tells you the EQUALIZER status.

To change the equalizer status, keep the EQUALIZER (G8) function key on the keyboard pressed and press the DATA button on the panel. The vocal guide tells you the EQUALIZER status (EQUALIZER ON or OFF).

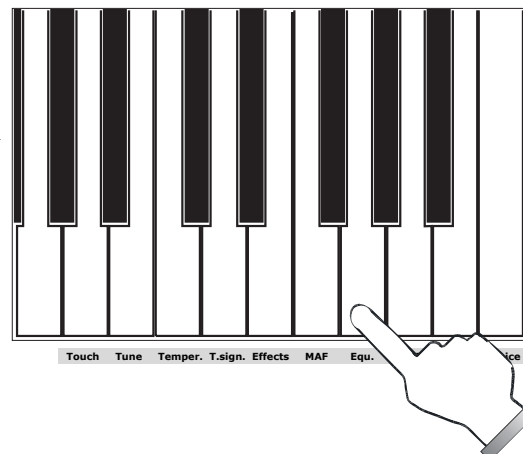
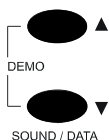

By default the function status is: EQUALIZER ON (enabled)

MIDI select MIDI channel: MIDI

With this function you can set the transmit and receive MIDI channel.

Keep the MIDI (A8) function key on the keyboard pressed and press the DATA buttons on the panel. The vocal guide signals MIDI.

Set the MIDI channel by pressing the corresponding key in the keyboard in a range from 01 to 16.

The default instrument MIDI channel set up is:

- 01** UPPER 1 (Main sound)
- 02** UPPER 2 (Dual sound)
- 03** LEFT (Bass or Lower sound)

The MIDI channels of the three sections (UPPER1, UPPER2, LEFT) are sequentially linked, by meaning that if you set MIDI channel **N** for UPPER1, you automatically set **N+1** for UPPER2 and **N+2** for LEFT.

For example if you set MIDI channel UPPER1 = 5, you have the following configuration:

- 05** UPPER 1 (Main sound)
- 06** UPPER 2 (Dual sound)
- 07** LEFT (Bass or Lower sound)

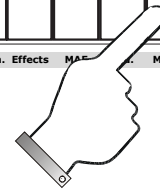
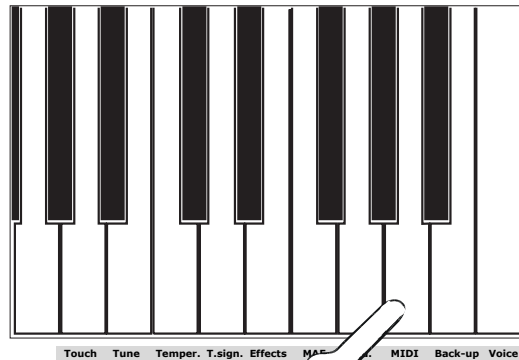

Back-Up on/off: Back Up

With this function you can decide if the piano default start set up will be factory set or user set.

Keep the Back-Up (B8) function key on the keyboard pressed and press the DATA button on the panel. The vocal guide signals the active Back-Up status.

To change the Back-Up status, keep the Back-Up (B8) function key on the keyboard pressed and press the DATA buttons on the panel. The vocal guide signals Back-Up status (Back-Up ON or OFF). The default instrument set up is: Back-Up ON (enabled).

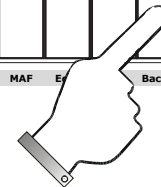
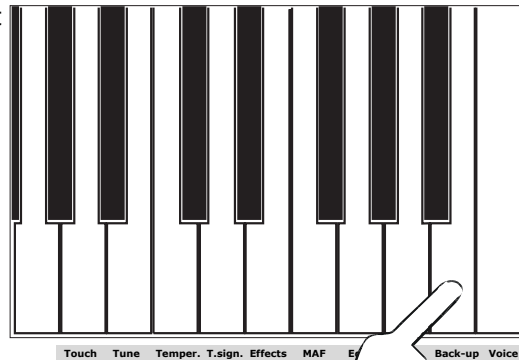
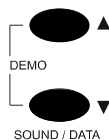

Vocal guide on/off: VOICE

The internal VP111/VP91 vocal guide system can be enabled or disabled, according to the personal likings of the player. The piano default set up is VOICE ON (enabled). Press the VOICE (C9) key on the keyboard and the DATA button on the control panel to disable the function.

Press the VOICE (C9) key on the keyboard and the DATA button on the control panel to reactivate the function.

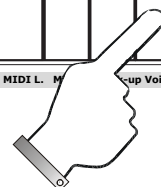
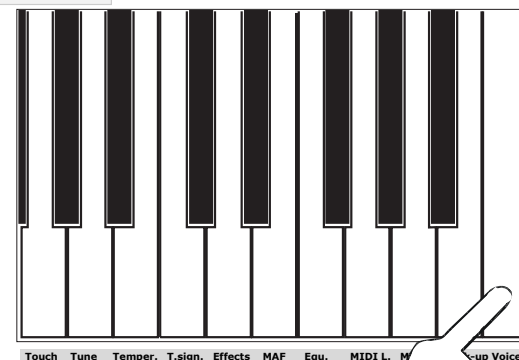
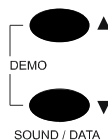

REAR PANNEL

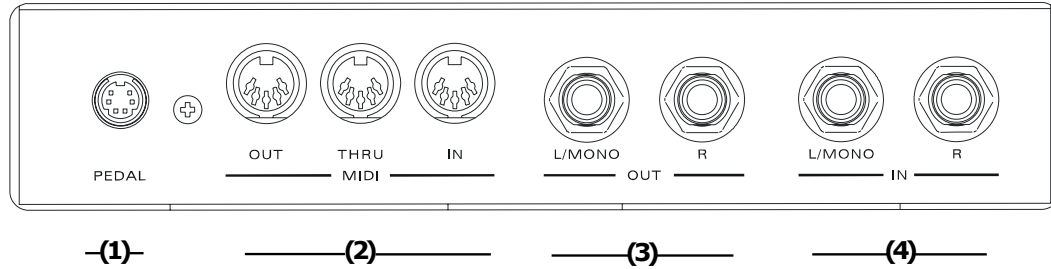

(1) PEDAL	Socket to connect the pedals (Damper, Soft, Sostenuto)
(2) MIDI In-Thru-Out	Standard MIDI connection
(3) MAIN OUT Right e Left/Mono	Connect the instrument to an external speaker system.
(4) INPUT Right e Left/Mono	Connect an instrument to the internal speaker system (CD, MIDI player, etc.)

Warning: the sound level of the external connected device it is not controlled by the master volume of your digital piano.

Technical Specifications

keyboard	88 keys with hammer action
poliphony	64 note max
sounds	11 presets + 5 combi
operating mode	Whole, Layer, Dual
controls	volume, demo, metronome, sound/data, transpose, preset and variation selection. Functions menu: Touch, global tune, temperament (3 types), Effects on/off, MAF on/off, equalizer on/off, midi menu (receive/transmit channel progr.), back up mode, Help.
technology	ISS ² piano technology MAF technology (Mechanical Acoustic Feel).
digital effects	4 reverber and 4 modulation ,associated to the presets
sequencer	metronome, demo songs.
connections	stereo in/out L (mono)/R, MIDI (In/thru/out), Headphone X 2, AC In
pedals	damper, soft, sostenuto
cabinet	Rosewood (with a sliding keyboard cover)
amplification	VP111: (25W + 25W) / VP91: (10W + 10W)
dimensions _(WxDxH)	VP111: (53,72" x 16,68" x 39,5") / VP91: (53,58" x 12,56" x 5")
weight	VP 111: 114,64 pounds / VP91: 41,89 pounds



graded
hammer
feeling



MAF technology
(Mechanical
Acoustic Feel).



ISS² piano technology



Speaking Help



Easy to use

MIDI implementation chart

VP111/VP91 Digital Piano		Version:1.00		
FUNCTION		TRANSMITTED	RECOGNIZED	REMARKS
BASIC CHANNEL	Default	1-16	1-16	Up to 3 channels at the same time in preset mode
	Changed	1-16	1-16	
MODE	Default	Mode 3	Mode 3	
	Messages Altered	X *****	Mode 3	
NOTE NUMBER	True Voice	0-127	0-127	
		21-108	21-108	
VELOCITY	Note ON	O	O	
	Note OFF	X	X	
AFTER TOUCH	Key's	X	X	
	Ch's	X	X	
CONTROL CHANGE	0	O	O	Bank Select MSB
	7	O	O	Main Volume
	11	O	O	Expression Contr.
	64	O	O	Damper Pedal
	66	O	O	Sustain Pedal
	67	O	O	Soft Pedal
	91	O	O	Reverb
	93	O	O	Chorus
	120	O	O	All Sound Off
123	O	O	All Note Off	
(*)				
PROGRAM CHANGE	True #	0-127	0-15	(*)
		0-15	0-15	
SYSTEM EXCLUSIVE		O	O	
SYSTEM REAL TIME	Clock	O	O	
	Commands	O	X	
AUX MESSAGES	Local On-Off	X	X	
	All Note Off	O	O	
	ActiveSense	O	O	
	Reset	X	X	
NOTES: (*) Message can be filtered				
Mode 1: Omni On, Poly		Mode 2: Omni On, Mono		O = YES
Mode 3: Omni Off, Poly		Mode 4: Omni Off, Mono		X = NO

Technical specifications are subject to change

FCC RULES

NOTE: This equipment has been tested and found to comply with the limits for a **Class B** digital Device, pursuant to Part 15 of the FCC Rules. These limits are designed to provide reasonable protection against harmful interference in a residential installation. This equipment generates, uses and can radiate radio frequency energy and, if not installed and used in accordance with the instruction, may cause harmful interference to radio communications. However, there is no guarantee that the interference will not occur in a particular installation. If this equipment does cause harmful interference to radio or television reception, which can be determined by turning the equipment off and on, the user is encouraged to try to correct the interference by one or more of the following measures:

- Reorient or relocate the receiving antenna.
- Increase the separation between the equipment and receiver.
- Connect the equipment into an outlet on a circuit different from that to which the receiver is connected.
- Consult the dealer or an experienced Radio/Tv technician for help.

The user is cautioned that any changes or modification not expressly approved by the party responsible for compliance could void the user's authority to operate the equipment.